

Z37/...

Mat.: 1.0718

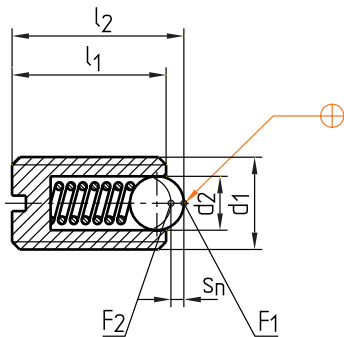

max. °C	d_2	s_n	F_1 [N]	F_2 [N]	l_2	d_1	l_1	Nr./No.
250	2,5	0,64	6	11,6	9,8	M 4	9	Z37/ 4x 9
	3	0,72	8,8	13,3	12,9	M 5	12	5x12
	3,5	0,8	11,2	15,1	15	M 6	14	6x14
	5	1,2	18,5	29,5	17,5	M 8	16	8x16
	6	1,6	23,9	43	21	M10	19	10x19
	8	2	35,9	59,8	24,5	M12	22	12x22
	10	2,4	74	101,6	27,5	M16	24	16x24

Z370/...

Mat.: 1.0718

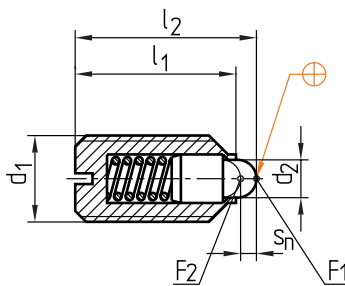

max. °C	d_2	s_n	F_1 [N]	F_2 [N]	l_2	d_1	l_1	Nr./No.
250	4	1,6	20	28	18	M 8	16	Z370/ 8x16
	4,5	2		36	21,5	M10	19	10x19
	6	2,8	25	48	25,5	M12	22	12x22
	8,5	3,6	50	76	28,5	M16	24	16x24
	10	5,2	89	112	36,5	M20	30	20x30

This is trial version
www.adultpdf.com